

HERCULES HOISTS LIMITED



Heavy Duty Wire Rope Hoist WRH Series

- ◆ Lifting
- ◆ Moving
- ◆ Storing



- ▶ Wide range
From 1 T SWL to 10 T SWL
- ▶ German origin, heavy duty Class IV design
Built for smooth operation even in toughest of applications
- ▶ Proven design with guaranteed safety and reliability.
- ▶ Robust gear system with precision machine cut case hardened alloy steel gears
Low noise operations over long life
- ▶ Unique and sturdy rope guide arrangement
Prevents rope slackening and easy change of rope
- ▶ Seamless pipe accurately machined rope drum
Long life to hoist
- ▶ Hoist and electric control design available for hazardous area application.
Extended application capability

Material Handling. Delivered.

Redefining Material Handling. Since 1962.

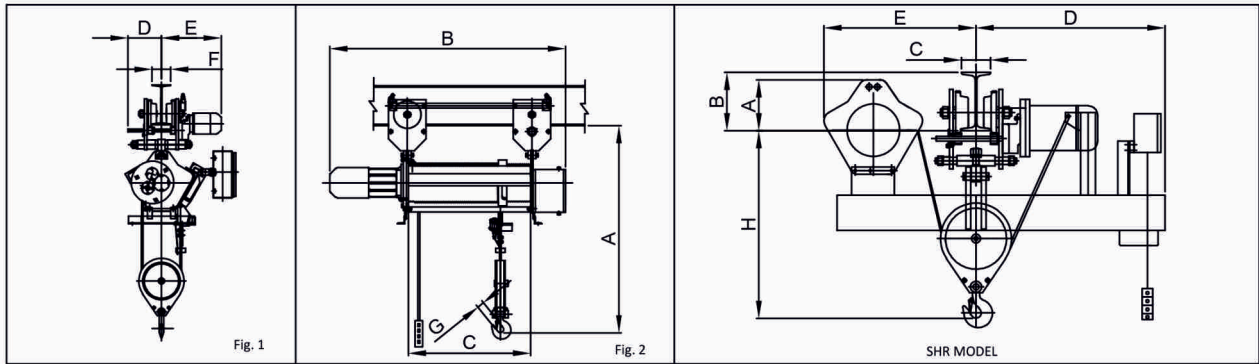

Type	WRH I			WRH II			WRH III			WRH I			WRH II			WRH III			WRH III						
Model	NP 101			NP 201			NP 301			NP 102			NP 202			NP 302			NP 303						
Class	IV			IV			IV			IV			IV			IV			IV						
S.W.L. (MT.)	1.0			2.0			3.0			2.0			4.0			5.0			6.0			7.5		10.0	
Lift (Mtrs.)	6	12	20	6.6	11.4	19.2	7	12	20	3	6	10	3.3	5.7	9.6	3.5	6	10	4	6	4	6			
Approx. Weight (Kg.)	264	286	322	386	414	459	533	546	568	296	318	354	478	497	563	638	818	828	900	1000					
Dim. B	1095	1305	1575	1190	1360	1630	1275	1445	1715	1095	1305	1575	1190	1360	1630	1275	1445	1715	1445	1715					
Dim. C (Drum Length)	345	545	815	383	553	823	383	553	823	345	545	815	383	553	823	383	553	823	553	823					
Wire Rope Dia. (mm)	8			11			14			8			11			14			14						
Hoist Speed m/min	9			8			8			4.5			4			4			2.66						
Hoist Motor H.P. (K.W.)/RPM	3 (2.2)/1500			5 (3.7)/1500			7.5 (5.5)/1500			3 (2.2)/1500			5 (3.7)/1500			7.5 (5.5)/1500			7.5 (5.5)/1500						
Trolley Speed m/min	17			17			17			17			17			17			17						
Trolley Motor H.P. (K.W.)/RPM	0.5 (0.37)/1000			0.5 (0.37)/1000			0.5 (0.37)/1000			0.5 (0.37)/1000			0.5 (0.37)/1000			0.75 (0.55)/1000			0.75 (0.55)/1000 X 2						
Trolley Wheel Dia./Qty.	140/4			140/4			140/4			140/4			140/4			140/4			140/4						
Min. Height of I beam (mm)	175			175			250			175			250			250			300						
F min.- max.	90-180			90-180			125-210			90-180			125-210			125-210			140-210						
A Head Room (+/-5%)	1300			1500			1600			1250			1500			1600			1950						
D	200			200			200			200			200			200			500						
E	650			650			650			650			650			650			650						
G	31			37			42			37			51			67			89						
Min. Req. Curvature Radius (mm)	550	850	1250	600	850	1250	600	850	1250	550	850	1250	600	850	1250	600	850	1250	850	1250					

SHR MODEL (Optional)

Model	Capacity	A (Max.)	B (Min.)	C		D (Max.)	E (Max.)	H (Min.)
				(Min.)	(Max.)			
WRH I	1T	260	300	140	210	650	550	600
	2T	260	300	140	210	650	600	650
WRH II	2T	300	350	140	210	1060	850	700
	4T/5T	300	350	140	210	1060	850	800
WRH III	3T	350	400	140	210	1250	900	750
	6T	350	400	140	210	1250	900	900

All dimensions are in mm

Data Tolerance ±10%.

NOTES:

- Optional travelling speed of 4.5, 8.5, 26 m/min. can be offered.
- Check 'I' Beam mounting arrangements, trolley plates will project 10mm above 'I' beam, if beam height is 150 mm.
- SHR Model is suitable for straight path only boggie can be supplier on request.
- Radius of curvature should not be S type or Z type bend with 90 Degree sharp bend.

Note :- Due to continuous development and improvement specification listed above may be changed without notice.

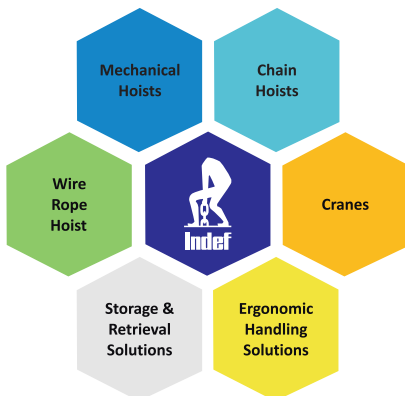

HERCULES HOISTS LIMITED

43/2B, Savroli-Kharpada Road, Dhamani, Khalapur - 410 202, Maharashtra, India

Regional offices: Chennai | Kolkata | New Delhi | Pune

Tel : +91 (0)2192 662511 | Fax: +91 (0) 2192 662504

www.indef.com | enquire@indef.com