

STIER RATCHET LEVER HOIST



RATCHET LEVER HOIST

FEATURES

- Capacity ranges from 0.5t to 9t
- Up to 5t in a single strand
- Galvanized and tempered high tensile load chain according to DIN EN 818-7-T
- Robust and compact product
- Integrated freewheel chain guide
- Ergonomic handle, additional screw connection
- Non-slip hand wheel
- Drop-forged load hook with a closed and fitted safety latch

USPs

- Allows easy free chaining and with selector level set at the middle position, pulling the load chain and hook becomes effortless
- High safety factor for the load chain
- Double guide rollers ensure higher resistance to inclined loading

BENEFITS

- Pleasing aesthetics, rust-free design and long chain life
- Being light weigh makes it easier to change the operational set-up in terms of handling and installation
- The chain guide leads effectively the load chain into the sprocket wheel without any jamming or sticking
- The protected hand grip ensures the hand doesn't slip or you hurt yourself
- High operating efficiency and assured reliability

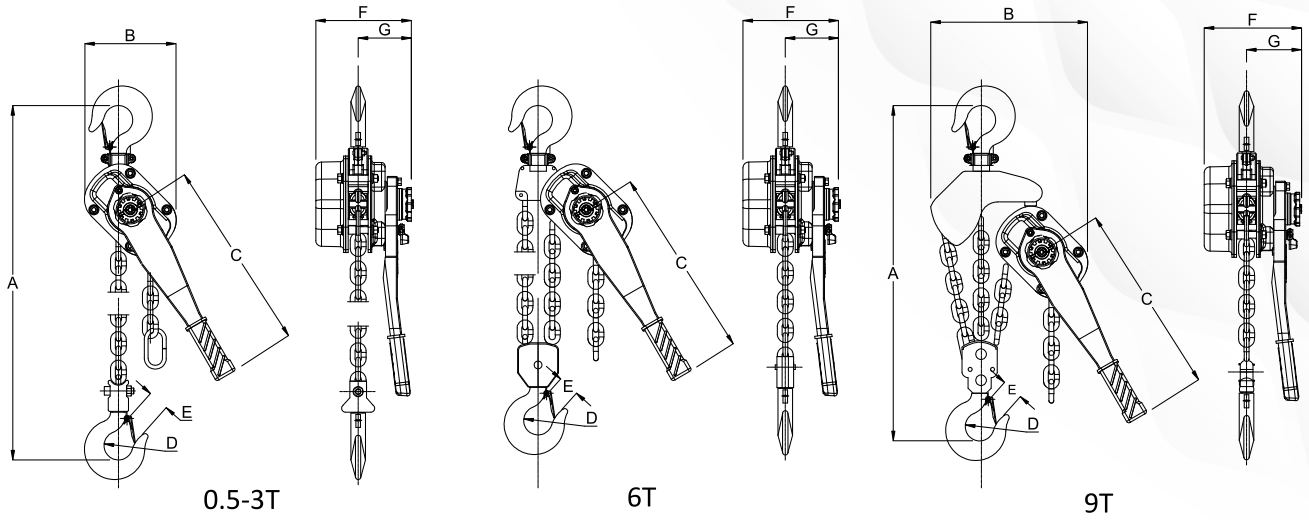

HHL/RLH Premium/20140201/V2

Capacity	t	0.75	1.5	3	6	9
Standard Lift	m	1.5	1.5	1.5	1.5	1.5
Min. headroom (A)	mm	330	400	520	640	795
Lever force	daN	26	29	33	37	42
Number of chain falls		1	1	1	2	3
Chain size	mm	5.6X17	7.1X21	09X27	09X27	09X27
B (Dimensions)	mm	132	145	199	230	338
C	mm	278	378	388	388	388
D	mm	35	42	50	53	67
E	mm	27	33	40	42	53
F	mm	148	173	200	200	200
G	mm	87	99	112	112	112
Weight with standard lift	kg	6.5	10.2	22	34	45
Lifting Height	kg	0.7	1.1	2.2	4.4	6.6

Note :- Due To Continuous development and improvement specification listed above may be changed without notice.

